

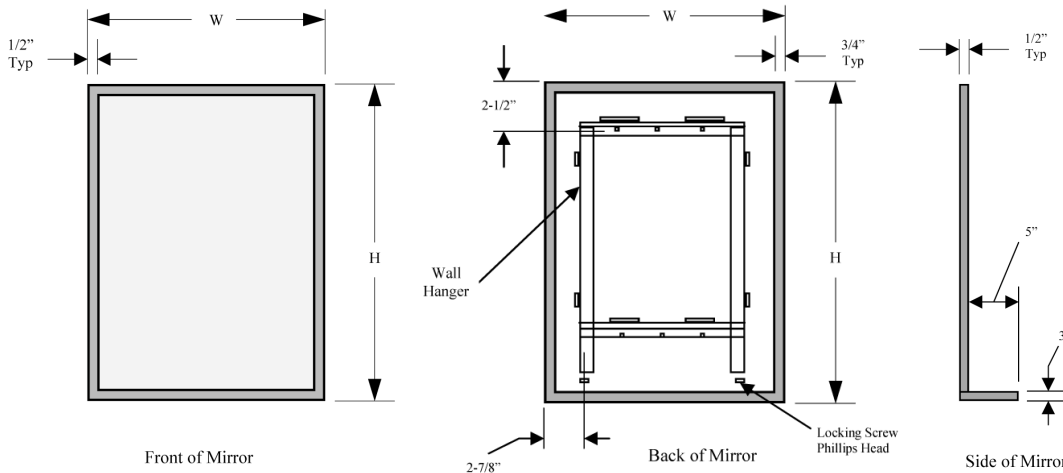

## Technical Data Sheet - M62 Series Mirror with Shelf



### Standard Size Mirrors

OVERALL SIZE W x H
16" x 20" (41 x 51 cm)
16" x 24" (41 x 61 cm)
18" x 24" (46 x 61 cm)
18" x 30" (46 x 76 cm)
18" x 36" (46 x 91 cm)
24" x 30" (61 x 76 cm)
24" x 36" (61 x 91 cm)

### MATERIALS:

**Frame** - Stainless Steel, 1/2" X 1/2" X 1/2" (13 x 13 x 13 mm) channel with polished finish. One-piece frame with 90° mitered corners. Galvanized Steel back with formed edges has horizontal mounting brackets located near top and bottom for hanging mirror. Locking devices secure mirror to concealed wall hanger. Concealed Philips-head locking screws securely fasten mirror to wall hanger.

**Shelf** - 18-8 S, type 304, 22 gauge (0.8 mm) stainless steel with satin finish. 3/8" (10 mm) return edges on front and sides with front edge hemmed for additional safety. Shelf is welded to mirror frame and reinforced by concealed 16 gauge (1.6 mm) stainless steel brackets. No exposed rivet heads, screws, or fasteners of any type appear on frame or shelf.

**Mirror** - No. 1 quality, 1/4" (0.6 mm) Float Glass selected for silvering, electrolytically copper-plated, guaranteed 10 years against silver spoilage. All edges protected by shock absorbing filler strips; back is protected by full shock-absorbing, water-resistant, non-abrasive 1/8" thick polystyrene padding.

**Concealed Wall Hanger** - 20 gauge (0.9 mm) prime galvanized steel.

### INSTALLATION:

Surface mounted, locks to concealed wall hanger. Wall hanger to be secured to wall at points across horizontal strap of hanger with screws furnished by Faries-McMeekan. For plaster or drywall on studs, provide concealed backing; backing must comply with local building codes. Hang mirror on wall hanger. Lock mirror to wall hanger by tightening Philips head locking screws in bottom of frame.

### SPECIFICATION:

Mirror shall be framed with one-piece Stainless Steel roll formed channel, 1/2" x 1/2" x 1/2" (13 x 13 x 13 mm), with 90° mitered corners. All exposed surfaces shall have polished finish. Shelf shall be type 304, 22 gauge (0.8 mm) stainless steel with satin finish and shall have 3/8" (10 mm) return edges on front and sides with front return edge hemmed. Shelf shall be welded to mirror frame and reinforced by concealed stainless steel brackets. No rivet heads, screws, or fasteners of any kind shall be exposed on frame or shelf. Float glass mirror shall be guaranteed 10 years against silver spoilage and all edges protected by shock absorbing, water resistant, non-abrasive 1/8" thick polystyrene padding. Galvanized steel back shall have integral horizontal hanging brackets located near the top and bottom. Mirror shall be secured to hanger with concealed Philips head locking screws in bottom of frame.

**Framed Mirror shall be model M62 \_\_\_\_\_ (insert width and height) of Faries-McMeekan, Inc., Elkhart, Indiana.**

### Special Notes:

1. Other sizes available as special order.
2. All Faries-McMeekan framed mirrors are made to overall width & height.
3. Faries-McMeekan mirrors are manufactured to a ± tolerance of 1/8" (3.2 mm).
4. To specify special sizes use Series number and width then height in inches. Ex. M62 1824
5. Provide 1" minimum clearance at bottom of mirror for engaging locking screws.
6. Maximum shelf length is 24".

Illustrations and descriptions herein are applicable to production as of the date of the Technical Data Sheet. The manufacturer reserves the right to and does from time to time make changes and improvements in designs and dimensions.